

1 **Can reptiles perceive visual illusions? Delboeuf illusion in red-footed tortoise**
2 ***(Chelonoidis carbonaria)* and bearded dragon *(Pogona vitticeps)***

3

4 Maria Santacà^{1*}, Maria Elena Miletto Petrazzini², Christian Agrillo¹ & Anna Wilkinson³

5 1) Department of General Psychology, University of Padova, Italy

6 2) School of Biological and Chemical Science, Queen Mary University of London, UK

7 3) School of Life Sciences, University of Lincoln, Lincoln, UK

8

9 **Corresponding author:* Maria Santacà. Department of General Psychology, Via Venezia 8, 35131
10 Padova (Italy). Phone: +39 0498277424, e-mail: santacamaria@gmail.com

11

12

13

14

15

16

17

18

19

20

21

22

23

24

25 **Abstract**

26 Optical illusions have been widely used to compare visual perception among vertebrates as they can reveal
27 how the system is able to adapt to visual input. Sensitivity to visual illusions has never been studied in reptiles.
28 Here we investigated whether red-footed tortoises, *Chelonoidis carbonaria*, and bearded dragons, *Pogona*
29 *vitticeps*, perceive the Delboeuf illusion. This illusion involves the misperception of the size of a target circle
30 depending upon the context in which it is presented. We adopted the same size discrimination for both species to
31 compare their performance. Animals were presented with two different types of trial. In control trials they received
32 two different-sized food portions on two plates of the same size. In test trials, they received two same-sized food
33 portions but presented on two different-sized plates. If they perceived the illusion in the same way as humans, we
34 expected them to select the food portion presented on the smaller plate. The tortoises exhibited poor performance
35 in the control trials which prevented us from drawing any conclusions about their perception of the Delboeuf
36 illusion. In contrast, the bearded dragons selected the larger amount of food in control trials. In test trials, they
37 selected the portion presented on the smaller plate significantly more often than chance, suggesting a human-like
38 sensitivity to the Delboeuf illusion. Our study provides the first evidence of the perception of a visual illusion in a
39 reptile species, suggesting that rather than simply detecting visual input, they interpret sensory information
40 captured by photoreceptors.

41
42
43
44
45
46
47
48
49

50 **Keywords:** reptile cognition; visual illusions; size illusions; Delboeuf illusion

51 **Introduction**

52 Animals are found in almost every habitat on earth and they have developed extraordinarily different eyes
53 and ways of seeing the world (Lazareva, Shimizu, & Wasserman, 2012). As such, it is essential to investigate
54 similarities and differences in perception between species. Optical illusions, subjective interpretations that differ
55 from physical stimulation, are becoming an increasingly popular tool to investigate animal visual perception (e.g.,
56 Feng, Chouinard, Howell, & Bennett, 2017; Kelley & Kelley, 2014). This approach allows us to assess whether
57 animals interpret visual inputs as humans do, or, whether they detect visual inputs with little or no variability (Feng
58 et al., 2017). Investigation of species differences in susceptibility to illusions may also shed light on the impact of
59 environmental and evolutionary pressures on visual perception (Feng et al., 2017).

60 The majority of the current work in this area has focused on mammals, such as chimpanzees [*Pan*
61 *troglodytes* (e.g. Fujita, 1997; Parrish & Beran, 2014)], rhesus monkeys [*Macaca mulatta* (e.g. Bayne & Davis,
62 1983; Fujita, 1997; Agrillo, Parrish, & Beran, 2014a; Agrillo, Parrish, & Beran, 2014b)], capuchin monkeys
63 [*Cebus apella* (e.g. Suganuma, Pessoa, Monge-Fuentes, Castro, & Tavares, 2007; Parrish, Agrillo, Perdue, &
64 Beran, 2016; Agrillo et al., 2014b)], baboons [*Papio papio* (Parron & Fagot, 2007)], ring-tailed lemurs [*Lemur*
65 *catta* (Santacà, Regaiolli, Miletto Petrazzini, Spiezio, & Agrillo, 2017)], dogs [*Canis familiaris* (e.g. Byosiere,
66 Feng, Woodhead, Rutter, Chouinard, Howell, & Bennett, 2017; Miletto Petrazzini, Bisazza, & Agrillo, 2017;
67 Keep, Zulch, & Wilkinson, 2018)] and bottlenose dolphins [*Tursiops truncatus* (Murayama, Usui, Takeda, Kato,
68 & Maejima, 2012)]. Only three species of birds have been investigated regarding their susceptibility to illusory
69 patterns: grey parrot [*Psittacus erithacus* (e.g. Pepperberg & Nakayama, 2016; Pepperberg, Vicinay, & Cavanagh,
70 2008), domestic chicks [*Gallus gallus* (e.g. Rosa Salva, Rugani, Cavazzana, Regolin, & Vallortigara, 2013;
71 Watanabe, Nakamura, & Fujita, 2013)] and pigeons [*Columba livia* (e.g. Nakamura, Watanabe, & Fujita, 2008;
72 Watanabe, Nakamura, & Fujita, 2011)]. In elasmobranchs only bamboo sharks have been studied [*Chiloscyllium*
73 *griseum* (e.g. Fuss, Bleckmann, & Schluessel, 2014; Fuss & Schlüssel, 2017)] while a larger range of teleost fishes
74 has been studied, including zebrafish [*Danio rerio* (e.g. Gori, Agrillo, Dadda, & Bisazza, 2014)], guppies [*Poecilia*
75 *reticulata* (e.g. Agrillo, Miletto Petrazzini, & Bisazza, 2016; Gori et al., 2014)], redbtail splitfin fish [*Xenotoca*
76 *eiseni* (e.g. Sovrano, Albertazzi, & Rosa Salva, 2015; Sovrano, & Bisazza, 2009; Sovrano, Da Pos, & Albertazzi,

77 2016)], goldfish [*Carassius auratus* (Wyzisk & Neumeyer, 2007)] and damselfish [*Chromis chromis* (e.g. Fuss &
78 Schlüssel, 2017)]. Susceptibility to illusory patterns was also studied in invertebrates, such as the perception of
79 illusory contours and contextual size illusions by honeybees [*Apis mellifera* (e.g. Horridge, Zhang, & O'Carroll,
80 1992; Howard, Avarguès-Weber, Garcia, Stuart-Fox, & Dyer 2017)]. Some of these species showed a human-like
81 perception of illusory phenomena, while others exhibited a reversed illusion, meaning that animals perceived a
82 sort of illusion but in the opposite way to human observers [e.g., pigeons (Nakamura et al., 2008; Watanabe et al.,
83 2011) and bantams (Watanabe et al., 2013)]. Furthermore, some species did not appear to perceive the illusion
84 [e.g., rhesus monkeys (Agrillo et al., 2014b); bamboo sharks (Fuss et al., 2014)]. However, in some cases there is
85 evidence that different methods of investigating illusion sensitivity can lead to different results in the same species.
86 One remarkable example is the case of bantam chickens and the Ebbinghaus illusion, a relative size perception
87 illusion. Rosa Salva et al. (2013) demonstrated that four-day-old chicks perceived the illusion in a human-like
88 direction, while Nakamura, Watanabe, and Fujita (2014) concluded the opposite testing 6-month-old chickens.

89 At this stage, no firm conclusions can be made regarding the universality of perceptual mechanisms, as
90 many species are yet to be studied. One specific class, the Reptilia, has not been investigated. Reptiles were long
91 considered to be sluggish and unintelligent, however, when tested under appropriate experimental conditions, they
92 exhibit an impressive array of cognitive abilities [e.g. red-footed tortoise, *Chelonoidis carbonaria*, and bearded
93 dragon, *Pogona vitticeps*, (Kis, Huber, & Wilkinson, 2015; Mueller-Paul, Wilkinson, Aust, Steurer, Hall, & Huber,
94 2014; Reviewed by Matsubara, Deeming, & Wilkinson, 2017; Wilkinson & Glass, in press)]. Work has recently
95 shown that these two species are able to perceive similarities between pictures and the objects that they represent
96 (Wilkinson, Mueller-Paul & Huber, 2013), respond to video stimuli (Wilkinson, Sebanz, Mandl, & Huber, 2011;
97 Siviter, Deeming, van Giezen, & Wilkinson, 2018) and, crucially for this experiment, discriminate between
98 different quantities of food reward (and remember this association for 18 months; Soldati, Burman, John, Pike, &
99 Wilkinson, 2017). This ability was also found in another reptile species, the Italian wall lizard, *Podarcis sicula*
100 (Miletto Petrazzini, Fraccaroli, Gariboldi, Agrillo, Bisazza, Bertolucci, & Foà, 2017).

101 This study therefore investigated how two reptile species, the red-footed tortoise (*Chelonoidis carbonaria*)
102 and the bearded dragon (*Pogona vitticeps*), perceive one of the most famous geometrical illusions, the Delboeuf

103 illusion. In the most familiar version of this illusion, two identical circles are near each other. One is encircled by
104 a circle with a small circumference while the other is encircled by a circle with a large circumference (Figure 1).
105 Humans tend to perceive the former as larger than the latter despite them being the same size (Pressey, 1977).
106 Similarly, capuchin monkeys (Parrish, Brosnan, Beran, 2015) have been shown to overestimate the size of a circle
107 when surrounded by a circle with a small circumference. In another version of the illusion, used with chimpanzees,
108 the target circles were replaced by food portions. Chimpanzees (Parrish & Beran, 2014) tended to overestimate
109 the dimension of a food portion included in the smaller array while they tended to underestimate the dimension of
110 the same food portion when it was presented in the larger array. Interestingly it has been demonstrated that humans'
111 perception of food portion is influenced by the Delboeuf pattern. Humans overestimate food sizes when food is
112 presented on small plates (e.g., Davis, Payne, & Bui, 2016; Van Ittersum & Wansink, 2007; Wansink & Cheney,
113 2005). In humans, the illusion seems to be a combination of both assimilation and contrast effects (King, 1988).
114 The food portion presented on the smaller plate is thought to assimilate to the contour of the plate, leading to it
115 being perceived as larger than it is; whereas the food portion presented on the larger plate is thought to contrast to
116 the contour of the plate, leading to an underestimation of the food portion size. In order to reduce the
117 methodological variability and make a reliable comparison between the different species, we adapted the same
118 spontaneous choice procedure adopted in the studies of chimpanzees (Parrish & Beran, 2014), lemurs (Santacà et
119 al., 2017) and dogs (Miletto Petrazzini, Bisazza, et al., 2017) to investigate this question in reptiles. In spontaneous
120 choice tests, animals are thought to exhibit their natural behaviour and their performance is likely to reflect the
121 cognitive and perceptual functions they would activate in nature. On the contrary, intensive training procedures
122 might lead to extraordinary performances through experience and the recruitment of other neural networks to
123 accommodate for the extensive requirements of a specific cognitive task (Agrillo & Bisazza, 2014).

124 Reptiles were observed spontaneously selecting one of two arrays containing food portions. We arranged
125 two different control trials, to verify the tendency of the subjects to maximize the food intake in our experimental
126 context, and test trials with the illusory pattern. In the control trials, we presented two different-sized food portions
127 [(with a ratio of 0.67 between them, a ratio commonly used in spontaneous discrimination tasks with animals,
128 including reptiles (e.g. Banszegi, Urrutia, Szenczi, & Hudson, 2016; Miletto Petrazzini & Wynne, 2016; Miletto

129 Petrazzini, Fraccaroli, et al., 2017)] on two same-sized arrays. In test trials, we presented two identical food
130 portions but on two different-sized arrays, one small and one large. If red-footed tortoises and bearded-dragons
131 perceived the Delboeuf illusion in a human-like way, they were expected to choose the portion presented on the
132 smaller array.

133

134 **Materials and methods**

135 *Subjects*

136 Eight red-footed tortoises (*Chelonoidis carbonaria*; 5 females and 3 males), and twelve bearded-dragons
137 (*Pogona vitticeps*; 8 females and 4 males), participated in this study (Table 1 and 2). The reptiles were maintained
138 at the School of Life Sciences, University of Lincoln. The tortoises were housed all together in a heated (28°C)
139 and humidified room while the bearded dragons were housed individually or in pairs in vivaria in an adjacent
140 room. All animals had permanent access to fresh water, shelter, UV light, and heat lamps. No subject was food
141 deprived during the experiment but they received a favored food reward during the experiment. All animals were
142 handled by humans on a daily basis. None of the subjects were experimentally naïve (e.g. Siviter, Deeming,
143 Rosenberger, Burman, Moszuti, & Wilkinson, 2017; Siviter et al., 2018; Soldati et al., 2017; Moszuti, Wilkinson,
144 & Burman, 2017), but they had not previously taken part in tests to investigate the susceptibility to visual illusions.
145 Each subject was tested individually.

146

147 *Stimuli and apparatus*

148 The stimuli consisted of mango jelly for the tortoises and vegetable extract (kale, cucumber and mint) jelly
149 for the bearded dragons, highly preferred food for both species. The jellies were prepared each day and cut with a
150 circular cutter to get a consistent round form. Then, each jelly was placed in the middle of a 7.5 x 8.5 cm black
151 plastic card. In each card one central white circle represented the plate. Two different sizes of plates were used:
152 the larger plates had a diameter of 4.92 cm while the smaller plates had a diameter of 1.83 cm. Two different
153 portion sizes were presented to the reptiles: the larger food portion was 1.5 cm in diameter (area = 1.77 cm²),
154 whereas the smaller food portion was 1.23 cm in diameter (area = 1.19 cm²). Each card was presented on a L-

155 shaped steel bracket (7.5 x 8.5 x 4 cm) in order to improve the visibility of the arrays from subjects' points of
156 view.

157 The experiments were run in an arena measuring 100 × 100 cm (Figure 2) located in a room maintained
158 at 28°C (+/- 3°C). To ensure the animals could see the entire array, they were positioned at the top of a ramp
159 inclined by a 36.02 degree angle with both food plates at the bottom. The same apparatus was used for both species
160 with two differences. For the tortoises, the inner part of the arena was all covered with grip and dark bark only in
161 the choice area, while for the bearded dragons it was entirely covered with black plastic. The arena was also
162 covered with a wire mesh for the bearded dragons to avoid the possibility of escaping from the apparatus. To
163 reduce the possibility of subjects using olfactory cues, the apparatus was cleaned after each trial.

164

165 *Procedure*

166 Before starting the test phase, each animal received a short familiarization phase. During the familiarization
167 phase, subjects were presented with a single card containing some pieces of jelly in the center of the choice area.
168 This procedure allowed us to habituate the animals to the cards, and to ensure they ate the jelly in the choice area.
169 All animals did this readily and therefore this phase lasted for only one day; each animal receive a total of 8 trials.
170 The test phase began as soon as the familiarization phase was complete. For the illusory investigation, reptiles
171 received 12 sessions, each consisting of four trials, receiving a total of 48 trials. They received two sessions each
172 day with at least a one-hour interval between sessions. Both control and test trials were presented to the subjects
173 (Figure 3), control trials were used to assess their motivation to choose the larger food portion. In half of the control
174 trials (Control A), the two different-sized portions of jelly were both on small plates, whilst in the other half
175 (Control B), they were presented on large plates. In these trials, the physical difference between the two portions
176 was equal to 0.67 (Banszegi et al., 2016; Luxon-Xiccato, Miletto Petrazzini, Agrillo, & Bisazza, 2015; Miletto
177 Petrazzini & Wynne, 2016; Miletto Petrazzini, Fraccaroli, et al., 2017). In contrast, in the test trials, the subjects
178 were presented with two same-sized jelly portions, one on a large plate and the other on a small plate. The ratio
179 between the area of the jelly and the smaller plate was equal to 0.67, a ratio commonly used in human research to
180 elicit the Delboeuf illusion (Piaget, 1957). In total, each subject was presented with 16 trials for each condition.

181 The sequence of presentation of the trials was pseudo-randomized with the restriction that the test trial was never
182 presented more than twice in a row and a session never began with a test trial. The position (left/right) of the larger
183 food portion in the control trials and of the plate size (large/small) in the test trials was counterbalanced across
184 trials. Each session was recorded and the videos were analysed to note the reptiles' choices (defined as the first
185 jelly touched by the animal and in the meantime the other jelly was removed). One third of the videos of both
186 species were analyzed by an additional observer and inter-rater reliability was excellent (Pearson's correlation $r =$
187 1.0 , $p < 0.0001$).

188 The results of this study left open the possibility that the bearded dragons learned to avoid as much white
189 as possible. Indeed, in control trials, the larger portion of food was intrinsically encircled by a smaller portion of
190 white plate; in test trials, the choice for the smaller plate was also characterized by the fact that a smaller portion
191 of the plate was visible in the chosen-array compared to the other option. To assess whether the subjects had learnt
192 the rule to choose the configuration with less white, we arranged an additional type of control trials (Control C),
193 presenting the two different-sized food portions in identical backgrounds without plates. (Figure 3.c). We tested 9
194 out of 12 bearded dragons (two had died of natural causes and one was unwell at the time of testing) adopting the
195 same procedure of the previous tests with the exception of receiving only one type of trials: they received two
196 sessions each day, each consisting of four trials, receiving a total of 16 trials of Control C. Therefore, the 9 bearded
197 dragons received a total of 64 trials divided in 16 trials for each condition. The sequence of presentation of the
198 trials was randomized with the restriction that the larger food portion was never presented more than twice in a
199 row in the same position (left/right).

200

201 *Data analysis*

202 Statistical analyses were performed using SPSS 24.0. Individual analyses were performed on the frequency
203 of choices of the larger food portion in the control trials and of the food portion presented on the smaller plate (the
204 apparently larger portion from a human perspective) in the test trials. Two-tailed chi-square tests ($\alpha = 0.05$) were
205 performed. Data were also analysed at population level. Not all data were normally distributed, hence we used
206 parametric statistics for the data normally distributed (Shapiro-Wilk test, $p > 0.05$) and non-parametric statistics

207 for the data that were not normally distributed (Shapiro-Wilk test, $p < 0.05$). One sample t-tests (chance level =
208 0.5) were performed to assess the discrimination of the two food portions in control trials and whether reptiles
209 selected the apparently larger food portion (to humans) more than chance in test trials. The performances in the
210 two types of control trials were compared using paired t-tests. To investigate a possible change in performance in
211 all types of trials over sessions, we performed an ANOVA.

212

213 **Results**

214 *Pogona vitticeps*

215 Individual analyses (chi-square tests) on the frequency of choices for the larger food portion showed that
216 9 bearded dragons out of 12 in Control A and 5 subjects in Control B significantly selected the larger food portion
217 (Table 1). Group analysis showed a significant discrimination of the larger quantity in both Control A (mean:
218 0.750, 95% CI [0.662, 0.838], one-sample Wilcoxon Signed Rank test $p = 0.003$) and Control B (mean: 0.703,
219 95% CI [0.655, 0.703], $t(11) = 9.275$, $p < 0.001$). No difference was found between the two control trials (Related-
220 sample Wilcoxon Signed Rank test $p = 0.162$).

221 In the test trials, individual analyses showed that 7 out of the 12 bearded dragons significantly selected the
222 food portion presented on the smaller plate (the one apparently larger to humans; Table 1). Group analyses also
223 showed a significant preference for the food portion presented on the smaller plate (mean: 0.703, 95% CI [0.640,
224 0.765], $t(11) = 7.294$, $p < 0.001$, Figure 4.a).

225 The ANOVA revealed a non significant difference in the bearded dragons' performance as a function of
226 time in all types of trials ($F_{(11, 12)} = 2.478$, $p = 0.0671$) indicating a lack of learning effect during the experiment.

227 In control C trials, individual analyses (chi-square tests) on the frequency of choices for the larger food
228 portion showed that 6 out of 9 bearded dragons significantly selected the larger food portion (Table 1). Group
229 analysis showed a significant discrimination of the larger quantity (mean: 0.757, 95% CI [0.696, 0.818], $t(8) =$
230 9.7167, $p < 0.01$, Figure 4.a). To further exclude the possibility that they simply learned to avoid as much white
231 as possible, we analyzed the performance in the first trial of control C: 8 out of 9 bearded dragons selected the
232 bigger food portion the first time they were presented with such trial. This result thus shows that bearded dragons

233 were not driven by a tendency to avoid as much white as possible, but instead they focused on the biologically-
234 relevant stimuli presented in the arrays, the food portions.

235

236 *Chelonoidis carbonaria*

237 Chi-square tests showed that only two tortoises significantly selected the larger food portion in Control A
238 and only one in Control B (Table 2). Contrary to expectations, one subject significantly selected the smaller portion
239 in Control A. Group analyses revealed the lack of significant preference for any portion size in either type of
240 control trial: Control A (mean: 0.547, 95% Confidence Interval CI [0.340, 0.694]; one-sample t-test $t(7) = 0.753$,
241 $p = 0.476$) and Control B (mean: 0.539, 95% CI [0.447, 0.631], $t(7) = 1.000$, $p = 0.351$). A paired t-test revealed
242 the absence of any differences between the two control trials ($t(7) = 0.099$, $p = 0.924$).

243 In the test trials, individual analyses revealed that tortoises did not significantly select one food portion
244 more than the other (Table 2). This result is confirmed by group analyses (mean: 0.516, 95% CI [0.449, 0.583],
245 one-sample Wilcoxon Signed Rank test $p = 0.705$, Figure 4.b).

246

247 **Discussion**

248 The present study represents the first attempt to investigate whether reptiles perceive visual illusions. To
249 achieve this goal, we tested two species, *Chelonoidis carbonaria* and *Pogona vitticeps*, with one of the most
250 popular size illusions from the human literature, the Delboeuf illusion. The findings revealed that the bearded
251 dragons were susceptible to the illusion and appeared to perceive it in a similar manner to humans and some other
252 species [e.g. chimpanzees (Parrish & Beran, 2014) and capuchin monkeys (Parrish et al., 2015)]; however, the
253 tortoises did not select the larger food portion when they differed in reality or when the difference was (potentially)
254 illusory.

255 In control trials, 10 out of 12 bearded dragons significantly selected the larger food portion in Control A
256 and 5 out of 12 in Control B. Bearded dragons' group analysis confirmed the discrimination of the larger quantity
257 with no difference in the two control trials. When presented with the test trials, individual (7 subjects out of 12)
258 and group analysis showed that bearded dragons selected the food portion included in the smaller plate suggesting

259 a human-like perception of the Delboeuf illusion. The results of Control C trials, where there were no white plates,
260 clearly demonstrated that subjects were not basing their choice on the basis of the quantity of white visible.

261 Our study provides the first evidence that a reptile species, *Pogona vitticeps*, perceives a visual illusion.
262 This indicates that, like some mammals, birds and fish, some reptiles can interpret and alter visual input related to
263 object size, rather than detecting visual inputs with little or no variability. The fact that bearded dragons perceive
264 this illusion suggests the existence of assimilation and contrast phenomena in reptiles, raising the intriguing
265 possibility that these perceptive mechanisms could be widely shared in the animal world. Also, the illusory
266 phenomenon requires the overall perception of the array (food portion and the surrounding array). However, only
267 few studies investigated the global and local precedence in animals. Chimpanzees and redbelly splitfin fish, such
268 humans, display a rather robust global-to-local precedence (e.g., Fujita & Matsuzawa, 1990; Hopkins, 1997;
269 Hopkins, & Washburn, 2002; Kimchi, 1992; Navon, 1977; Truppa, Sovrano, Spinozzi, & Bisazza, 2010) and they
270 both demonstrated perception of respectively the Delboeuf and the Ebbinghaus illusion as human observers. In
271 contrast, local-to-global precedence was found in other species (e.g., capuchin monkeys, De Lillo, Palumbo,
272 Spinozzi, & Giustino, 2001; pigeons: Cavoto & Cook, 2001) that do not display susceptibility to the Delboeuf
273 Illusion. In this context, dogs (Miletto Petrazzini et al., 2017), showed a larger inter-individual variability than
274 humans and non-significant trend for global precedence (Pitteri, Mongillo, Carnier, & Marinelli, 2014). Given the
275 lack of studies investigating this phenomenon, no firm conclusion can be drawn regarding the relationship between
276 the global/local precedence and the perception of the Delboeuf illusion. What can be claimed is that the global-to-
277 local precedence is a prerequisite but not a predictor of the illusory sensitivity. Although no study has investigated
278 whether reptiles show global-to-local precedence, the results of our study suggest the existence of a global-to-
279 local precedence in bearded dragons.

280 In contrast, this procedure proved to be less successful for studying the perception of the Delboeuf illusion
281 in red-footed tortoises. In control trials, only two tortoises (Savina and Charles Darwin) significantly selected the
282 larger food portion in control A and only one (Gerard) in control B; in control A one tortoise (Ranieri) selected
283 the smaller one instead. This performance was confirmed by group analyses that indicated no significant choice
284 for any food portion in both types of control trials. These results suggest that, within this context, the tortoises did

285 not maximize their food intake; therefore, we cannot draw any conclusion about their perception of the Delboeuf
286 illusion. Why did tortoises exhibit such a poor performance? This species has been shown to optimize food intake
287 previously and will work harder for both larger and favoured food rewards, further, they are able to retain
288 information about stimuli associated with a greater food reward for at least 18 months (Soldati et al., 2017). It is
289 possible that because both portion sizes used in this experiment were large (and were substantially larger than
290 those used by Soldati et al., 2017) that they either did not need to maximize their intake or they were trying to
291 maximize food intake but the physical difference between the food portions presented in control trials (ratio of
292 0.67) was too subtle to be detected. There is currently no literature regarding the discrimination ratios in this
293 species. If the red-footed tortoises did not discriminate a 0.67 ratio, it is likely that they would not perceive a
294 subjective difference between the two food portions in the Delboeuf pattern. The position of the stimuli in the
295 experimental arena could be another factor influencing their performance. Although the ramp was designed to
296 maximize the animals' view of the entire array, perhaps this was not optimal for the tortoises.

297 Finally, we acknowledge our limited sample size of tortoises ($N = 8$) – although similar to the sample size
298 used in the previous studies that investigated the spontaneous emergence of the Delboeuf illusion in other species
299 (Beran & Parrish, 2014; Miletto Petrazzini et al., 2017). Despite the limitations of a small sample, we suggest that
300 the null results observed in tortoises could easily reflect an unidentified feature of our methodology. After
301 determining red-footed tortoises' size discrimination abilities, one could, adopting different methodologies (e.g.
302 training procedures or different size/position of the stimuli), investigate again their perception of the Delboeuf
303 illusion.

304 The importance of reducing methodological variability is a well-known and highly debated issue in
305 scientific community, especially in the investigation of cognitive abilities of vertebrates (e.g. Agrillo & Bisazza,
306 2014; Feng et al., 2017). However as emerged in this study, the use of the same procedure and setting may prevent
307 a reliable comparison. The use of multiple methodological approaches (e.g., free choice tests vs. operant
308 conditioning procedure, use of food vs. two-dimensional figures as stimuli) is necessary to compare the subjective
309 world of different species.

310

311 **Acknowledgements**

312 We thank the University of Lincoln Minster House technical team, in particular Paul Sheridan, for their
313 help with animal care and setup. This study was supported by ‘STARS@unipd’ (ANIM_ILLUS) grant from the
314 University of Padova to C.A and by Marie Skłodowska-Curie individual fellowship (SBCN1E4R) from the
315 European Union’s Horizon 2020 to Maria Elena Miletto Petrazzini. We also thank all the students that helped with
316 the video analysis.

317

318 *Ethical Note*

319 This research was approved by the ethics committee of the School of Life Sciences, University of
320 Lincoln (CoSREC364). Applicable national guidelines for the care and use of animals were followed.

321

322

323

324 **References**

- 325 Agrillo, C., & Bisazza, A. (2014). Spontaneous versus trained numerical abilities. A comparison between the two
326 main tools to study numerical competence in non-human animals. *Journal of Neuroscience Methods*, *234*,
327 82 – 91.
- 328 Agrillo, C., Miletto Petrazzini, M. E., & Bisazza, A. (2016). Brightness illusion in the guppy (*Poecilia*
329 *reticulata*). *Journal of Comparative Psychology*, *130*(1), 55.
- 330 Agrillo, C., Parrish, A. E., & Beran, M. J. (2014). Do rhesus monkeys (*Macaca mulatta*) perceive the Zöllner
331 illusion?. *Psychonomic Bulletin & Review*, *21*(4), 986-994.
- 332 Agrillo, C., Parrish, A. E., & Beran, M. J. (2014b). Do primates see the solitaire illusion differently? A comparative
333 assessment of humans (*Homo sapiens*), chimpanzees (*Pan troglodytes*), rhesus monkeys (*Macaca*
334 *mulatta*), and capuchin monkeys (*Cebus apella*). *Journal of Comparative Psychology*, *128*, 402 – 413.
- 335 Banszegi, O., Urrutia, A., Szenczi, P., & Hudson, R. (2016). More or less: Spontaneous quantity discrimination in
336 the domestic cat. *Animal Cognition*, *19*, 879 – 888.
- 337 Bayne, K. L., & Davis, R. (1983). Susceptibility of rhesus monkeys (*Macaca mulatta*) to the Ponzo illusion.
338 *Bulletin of the Psychonomic Society*, *21*, 476 – 478.
- 339 Byosiere, S. E., Feng, L. C., Woodhead, J. K., Rutter, N. J., Chouinard, P. A., Howell, T. J., & Bennett, P. C.
340 (2017). Visual perception in domestic dogs: susceptibility to the Ebbinghaus–Titchener and Delboeuf
341 illusions. *Animal Cognition*, *20*(3), 435-448.
- 342 Cavoto, K. K., & Cook, R. G. (2001). Cognitive precedence for local information in hierarchical stimulus
343 processing by pigeons. *Journal of Experimental Psychology: Animal Behavior Processes*, *27*, 3-16.
- 344 Davis, B., Payne, C. R., & Bui, M. (2016). Making small food units seem regular: How larger table size reduces
345 calories to be consumed. *Journal of the Association of Consumer Research*, *1*, 115 – 124.
- 346 De Lillo, C., Spinozzi, G., Palumbo, M., & Giustino, G. (2011). Attention allocation modulates the processing of
347 hierarchical visual patterns: A comparative analysis of capuchin monkeys (*Cebus apella*) and humans.
348 *Journal of Experimental Psychology: Animal Behavior Processes*, *37*(3), 341.

349 Faul, F., & Erdfelder, E. (1992). GPOWER: A priori, post-hoc, and compromise power analyses for MS-DOS
350 [Computer software]. *Bonn, Germany: Bonn University, Department of Psychology.*

351 Feng L. C., Chouinard P. A., Howell T. J., & Bennett P. C. (2017). Why do animals differ in their susceptibility
352 to geometrical illusions? *Psychonomic Bulletin & Review*, *24*, 262 – 276.

353 Fujita, K. (1997). Perception of the Ponzo illusion by rhesus monkeys, chimpanzees, and humans: Similarity and
354 difference in the three primate species. *Perception & Psychophysics*, *59*, 284 – 292.

355 Fujita, K., & Matsuzawa, T. (1990). Delayed figure reconstruction by a chimpanzee (*Pan troglodytes*) and humans
356 (*Homo sapiens*). *Journal of Comparative Psychology*, *104*(4), 345-351.

357 Fuss, T., & Schlüssel, V. (2017). The Ebbinghaus illusion in the gray bamboo shark (*Chiloscyllium griseum*) in
358 comparison to the teleost damselfish (*Chromis chromis*). *Zoology*, *123*, 16-29.

359 Fuss, T., Bleckmann, H., & Schluessel, V. (2014). The brain creates illusions not just for us: Sharks (*Chiloscyllium*
360 *griseum*) can “see the magic” as well. *Frontiers in Neural Circuits*, *8*, 24.

361 Gori, S., Agrillo, C., Dadda, M., & Bisazza, A. (2014). Do fish perceive illusory motion? *Scientific Reports*, *4*.

362 Hopkins, W. D. (1997). Hemispheric specialization for local and global processing of hierarchical visual stimuli
363 in chimpanzees (*Pan troglodytes*). *Neuropsychologia*, *35*(3), 343-348.

364 Hopkins, W. D., & Washburn, D. A. (2002). Matching visual stimuli on the basis of global and local features by
365 chimpanzees (*Pan troglodytes*) and rhesus monkeys (*Macaca mulatta*). *Animal Cognition*, *5*, 27–31.

366 Horridge, G. A., Zhang, S. W., & O'Carroll, D. (1992). Insect perception of illusory contours. *Philosophical*
367 *Transactions of the Royal Society of London B*, *337*(1279), 59-64.

368 Howard, S. R., Avarguès-Weber, A., Garcia, J. E., Stuart-Fox, D., & Dyer, A. G. (2017). Perception of contextual
369 size illusions by honeybees in restricted and unrestricted viewing conditions. *Proceedings of the*
370 *Royal Society B*, *284*(1867), 20172278.

371 Keep, B., Zulch, H. E., & Wilkinson, A. (2018). Truth is in the eye of the beholder: Perception of the Müller-Lyer
372 illusion in dogs. *Learning & Behavior*, *46*(4), 501-512.

373 Kelley, L. A., & Kelley, J. L. (2014). Animal visual illusion and confusion: the importance of a perceptual
374 perspective. *Behavioral Ecology*, *25*(3), 450-463.

- 375 Kimchi, R. (1992). Primacy of wholistic processing and global/local paradigm: A critical review. *Psychological*
376 *Bulletin*, 112(1), 24.
- 377 King, D. L. (1988). Assimilation is due to one perceived whole and contrast is due to two perceived wholes. *New*
378 *Ideas in Psychology*, 6(3), 277-288.
- 379 Kis, A., Huber, L., & Wilkinson, A. (2015). Social learning by imitation in a reptile (*Pogona vitticeps*). *Animal*
380 *Cognition*, 18(1), 325-331.
- 381 Lazareva, O. F., Shimizu, T., & Wasserman, E. A. (Eds.). (2012). How animals see the world: Comparative
382 behavior, biology, and evolution of vision. *Oxford University Press*.
- 383 Lucon-Xiccato, T., Miletto Petrazzini, M. E., Agrillo, C., & Bisazza, A. (2015). Guppies discriminate between
384 two quantities of food items but prioritize item size over total amount. *Animal Behaviour*, 107, 183 – 191.
- 385 Matsubara, S., Deeming, D. C., & Wilkinson, A. (2017). Cold-blooded cognition: new directions in reptile
386 cognition. *Current Opinion in Behavioral Sciences*, 16, 126-130.
- 387 Miletto Petrazzini, M. E., & Wynne, C. D. (2016). What counts for dogs (*Canis lupus familiaris*) in a quantity
388 discrimination task? *Behavioural Processes*, 122, 90 – 97.
- 389 Miletto Petrazzini, M. E., Bisazza, A., & Agrillo, C. (2017). Do domestic dogs (*Canis lupus familiaris*) perceive
390 the Delboeuf illusion? *Animal Cognition*, 20(3), 427-434.
- 391 Miletto Petrazzini, M. E., Fraccaroli, I., Gariboldi, F., Agrillo, C., Bisazza, A., Bertolucci, C., & Foà, A. (2017).
392 Quantitative abilities in a reptile (*Podarcis sicula*). *Biology Letters*, 13, 20160899.
- 393 Moszuti, S. A., Wilkinson, A., & Burman, O. H. (2017). Response to novelty as an indicator of reptile welfare.
394 *Applied Animal Behaviour Science*, 193, 98-103.
- 395 Mueller-Paul, J., Wilkinson, A., Aust, U., Steurer, M., Hall, G., & Huber, L. (2014). Touchscreen performance
396 and knowledge transfer in the red-footed tortoise (*Chelonoidis carbonaria*). *Behavioural Processes*, 106,
397 187-192.
- 398 Murayama, T., Usui, A., Takeda, E., Kato, K., & Maejima, K. (2012). Relative size discrimination and perception
399 of the Ebbinghaus illusion in a bottlenose dolphin (*Tursiops truncatus*). *Aquatic Mammals*, 38(4), 333.

400 Nakamura, N., Watanabe, S., & Fujita, K. (2008). Pigeons perceive the Ebbinghaus-Titchener circles as an
401 assimilation illusion. *Journal of Experimental Psychology: Animal Behavior Processes*, *34*, 375 – 387.

402 Nakamura, N., Watanabe, S., & Fujita, K. (2014). A reversed Ebbinghaus–Titchener illusion in bantams (*Gallus*
403 *gallus domesticus*). *Animal Cognition*, *17*(2), 471-481.

404 Navon, D. (1977). Forest before trees: The precedence of global features in visual perception. *Cognitive*
405 *Psychology*, *9*(3), 353-383.

406 Parrish, A. E., & Beran, M. J. (2014). When less is more: like humans, chimpanzees (*Pan troglodytes*) misperceive
407 food amounts based on plate size. *Animal Cognition*, *17*(2), 427-434.

408 Parrish, A. E., Agrillo, C., Perdue, B. M., & Beran, M. J. (2016). The elusive illusion: Do children (*Homo sapiens*)
409 and capuchin monkeys (*Cebus apella*) see the Solitaire illusion? *Journal of Experimental Child*
410 *Psychology*, *142*, 83 – 95.

411 Parrish, A. E., Brosnan, S. F., & Beran, M. J. (2015). Do you see what I see? A comparative investigation of the
412 Delboeuf illusion in humans (*Homo sapiens*), rhesus monkeys (*Macaca mulatta*), and capuchin monkeys
413 (*Cebus apella*). *Journal of Experimental Psychology: Animal Learning and Cognition*, *41*, 395 – 405.

414 Parron, C., & Fagot, J. (2007). Comparison of grouping abilities in humans (*Homo sapiens*) and baboons (*Papio*
415 *papio*) with the Ebbinghaus illusion. *Journal of Comparative Psychology*, *121*(4), 405.

416 Pepperberg, I. M., & Nakayama, K. (2016). Robust representation of shape in a Grey parrot (*Psittacus*
417 *erithacus*). *Cognition*, *153*, 146-160.

418 Pepperberg, I. M., Vicinay, J., & Cavanagh, P. (2008). Processing of the Müller-Lyer illusion by a grey parrot
419 (*Psittacus erithacus*). *Perception*, *37*, 765 – 781.

420 Piaget, J. (1957). *Les Mécanismes Perceptifs*. Paris: Presses Universitaires de France.

421 Pitteri, E., Mongillo, P., Carnier, P., & Marinelli, L. (2014). Hierarchical stimulus processing by dogs (*Canis*
422 *familiaris*). *Animal Cognition*, *17*(4), 869-877.

423 Pressey, A. W. (1977). Measuring the Titchener circles and Delboeuf illusions with the method of adjustment.
424 *Bulletin of the Psychonomic Society*, *10*(2), 118-120.

425 Rosa Salva, O., Rugani, R., Cavazzana, A., Regolin, L., & Vallortigara, G. (2013). Perception of the Ebbinghaus
426 illusion in four-day-old domestic chicks (*Gallus gallus*). *Animal Cognition*, *16*, 895 – 906.

427 Santacà, M., Regaiolli, B., Miletto Petrazzini, M. E., Spiezio, C., & Agrillo, C. (2017). Preliminary study to
428 investigate the Delboeuf illusion in ring-tailed lemurs (*Lemur catta*): Methodological challenges. *Animal*
429 *Behavior and Cognition*, *4*(3), 365-377.

430 Siviter, H., Deeming, D. C., Rosenberger, J., Burman, O. H. P., Moszuti, S. A., & Wilkinson, A. (2017). The
431 impact of egg incubation temperature on the personality of oviparous reptiles. *Animal Cognition*, *20*(1),
432 109–116. <http://doi.org/10.1007/s10071-016-1030-1>

433 Siviter, H., Deeming, D. C., van Giezen, M. F. T. & Wilkinson, A. (2018). Incubation environment impacts the
434 social cognition of adult lizards. *Royal Society Open Science*

435 Soldati, F., Burman, O. H. P., John, E. A., Pike, T. W., & Wilkinson, A. (2017). Long-term memory of relative
436 reward values. *Biology Letters*, *13*(2), 20160853. <http://doi.org/10.1098/rsbl.2016.0853>

437 Sovrano, V. A., & Bisazza, A. (2009). Perception of subjective contours in fish. *Perception*, *38*(4), 579-590.

438 Sovrano, V. A., Albertazzi, L., & Salva, O. R. (2015). The Ebbinghaus illusion in a fish (*Xenotoca eiseni*). *Animal*
439 *Cognition*, *18*(2), 533-542.

440 Sovrano, V. A., Da Pos, O., & Albertazzi, L. (2016). The Müller-Lyer illusion in the teleost fish *Xenotoca*
441 *eiseni*. *Animal Cognition*, *19*(1), 123-132.

442 Suganuma, E., Pessoa, V. F., Monge-Fuentes, V., Castro, B. M., & Tavares, M. C. H. (2007). Perception of the
443 Müller–Lyer illusion in capuchin monkeys (*Cebus apella*). *Behavioural Brain Research*, *182*, 67 – 72.

444 Truppa, V., Sovrano, V. A., Spinozzi, G., & Bisazza, A. (2010). Processing of visual hierarchical stimuli by fish
445 (*Xenotoca eiseni*). *Behavioural Brain Research*, *207*(1), 51-60.

446 Van Ittersum, K., & Wansink, B. (2007). Do children really prefer large portions? Visual illusions bias their
447 estimates and intake. *Journal of the American Dietetic Association*, *107*, 1107 – 1110.

448 Wansink, B., & Cheney, M. M. (2005). Super bowls: Serving bowl size and food consumption. *The Journal of the*
449 *American Medical Association*, *293*, 1727 – 1728.

- 450 Watanabe, S., Nakamura, N., & Fujita, K. (2011). Pigeons perceive a reversed Zöllner illusion. *Cognition*, *119*,
451 137 – 141.
- 452 Watanabe, S., Nakamura, N., & Fujita, K. (2013). Bantams (*Gallus gallus domesticus*) also perceive a reversed
453 Zöllner illusion. *Animal Cognition*, *16*, 109 – 115.
- 454 Wilkinson, A., & Glass, E. (in press). Cold-blooded Cognition: How to get a tortoise out of its shell. Field and
455 Laboratory Methods in Animal Cognition. *Cambridge University Press*, UK.
- 456 Wilkinson, A., & Huber, L. (2012). Cold-blooded cognition: reptilian cognitive abilities. *The Oxford Handbook*
457 *of Comparative Evolutionary Psychology*. *Oxford University Press*, *New Jersey*, 129-143.
- 458 Wilkinson, A., Mueller-Paul, J., & Huber, L. (2013). Picture–object recognition in the tortoise *Chelonoidis*
459 *carbonaria*. *Animal Cognition*, *16*(1), 99-107.
- 460 Wilkinson, A., Sebanz, N., Mandl, I., & Huber, L. (2011). No evidence of contagious yawning in the red-footed
461 tortoise *Geochelone carbonaria*. *Current Zoology*, *57*(4), 477-484.
- 462 Wyzisk, K., & Neumeier, C. (2007). Perception of illusory surfaces and contours in goldfish. *Visual*
463 *Neuroscience*, *24*(3), 291-298.
- 464
- 465

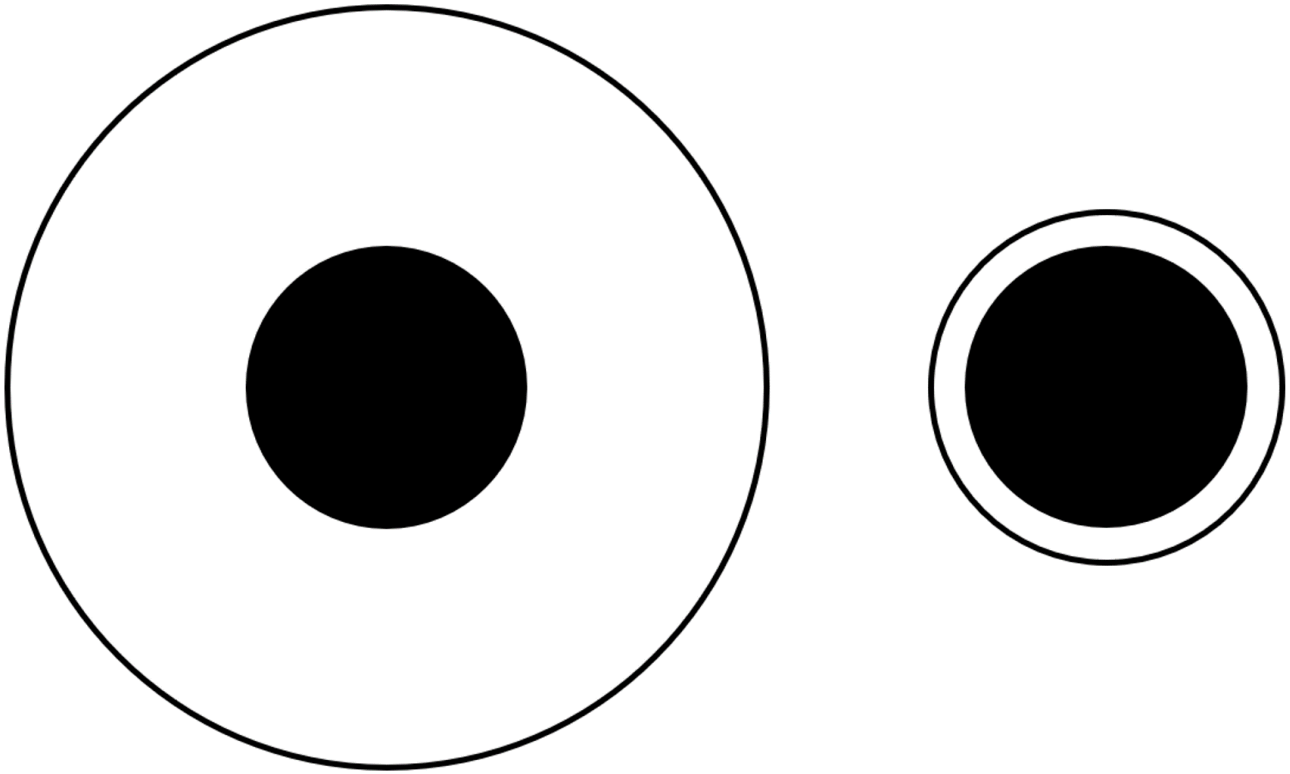

467

468 **Figure 1. Delboeuf illusion.** This illusion occurs when two same-sized circles are perceived to be different
469 depending on the context in which they are presented. In the classical version the central target circles are
470 physically identical, but human observers typically underestimate the size of the one included in the larger ring
471 and tend to overestimate the size of the one encompassed by the smaller ring.

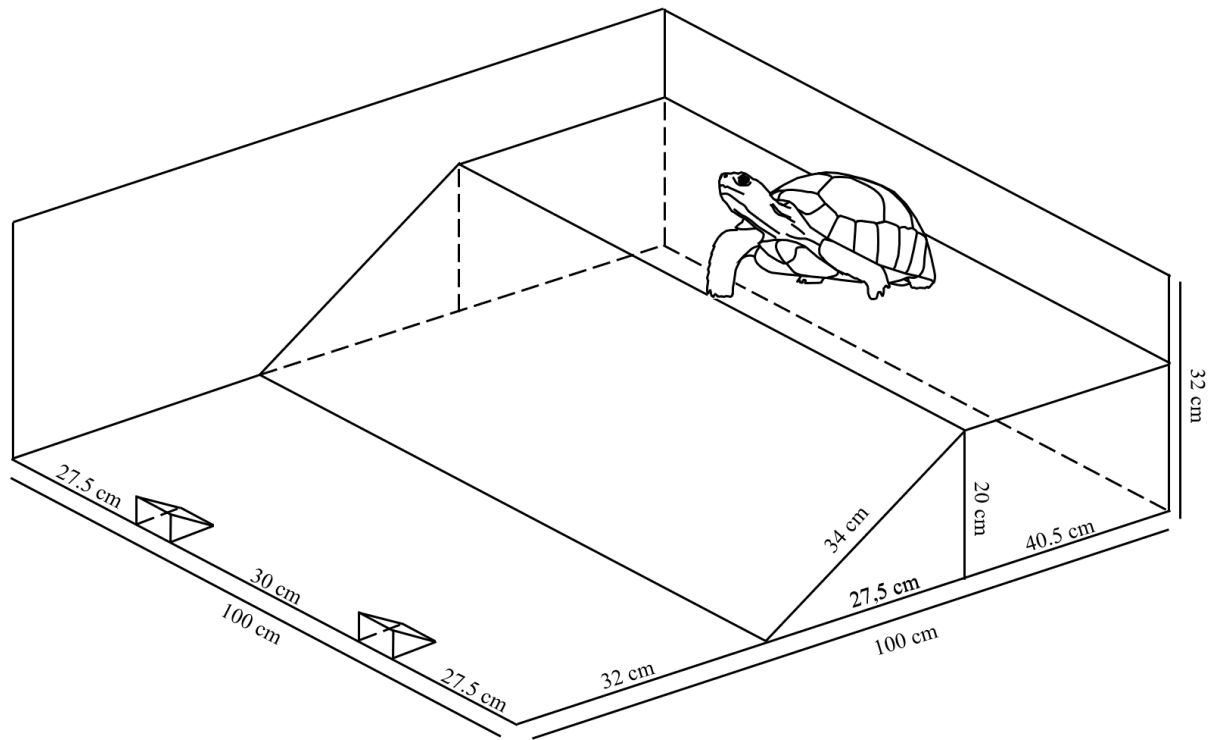

472

473 **Figure 2. Experimental setup.** Three-dimensional representation of the experimental apparatus. Subjects
474 had to descend a ramp in order to reach the plates containing the jellies. As dependent variable we recorded the
475 first food portion touched by the animal in each trial.

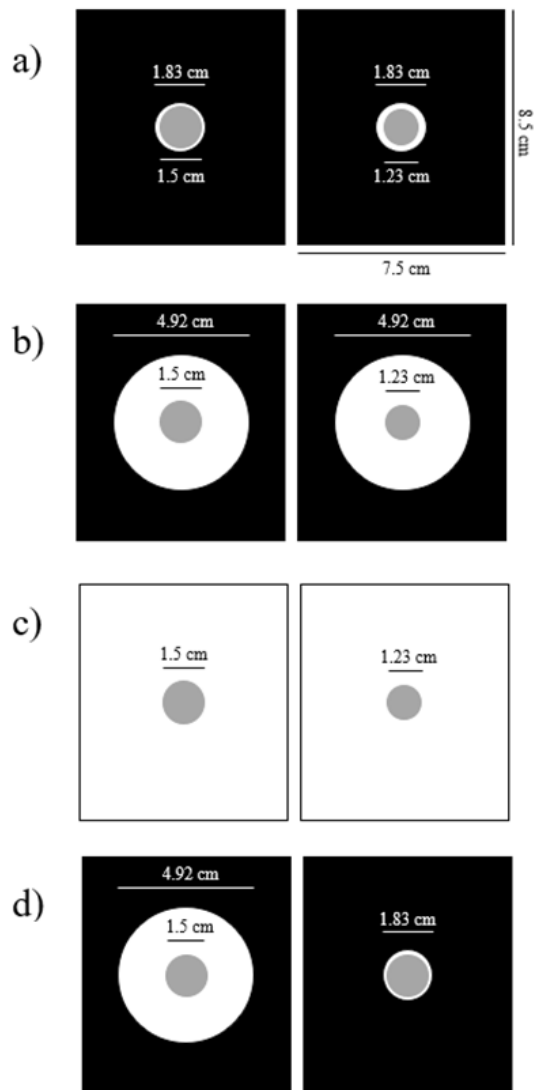

476

477

478

479

480

481

482

483

484

Figure 3. Stimuli. Different or equal-sized food portions were presented on white plates: (a) control A (different food portions in two identical small plates); (b) control B (different food portions in two identical large plates); (c) control C (different food portions in identical neutral backgrounds); (d) test trials (equal-sized food portions in two different-sized plates).

A. *Pogona vitticeps*

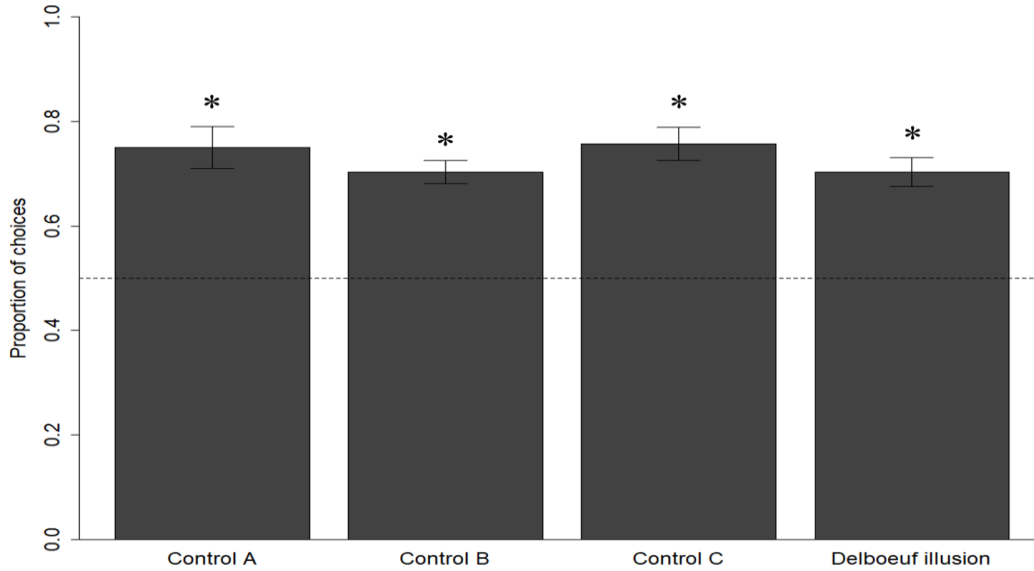

B. *Chelonoidis carbonaria*

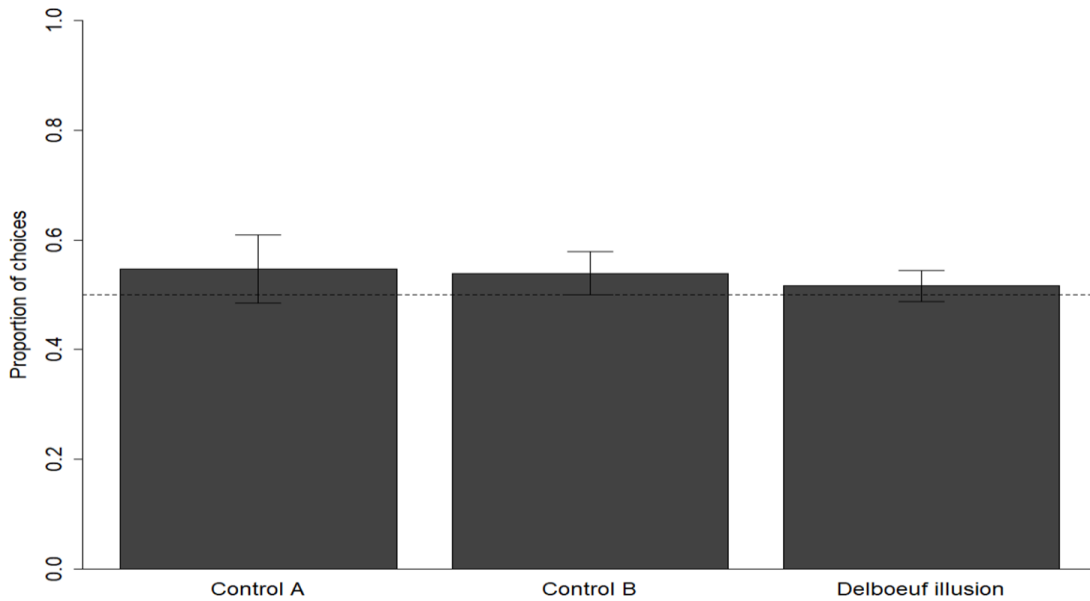

485

486

487

488

489

490

491

Figure 4. Results. The Y-axis refers to the proportion of choices for the larger food portion in the control trials and the proportion of choices for the food portion presented on the small plate in the test trials. Bearded dragons (a), but not tortoises (b), selected the larger food portion in all control trials. Tortoises did not show a preference for any portion in test trials (b) while bearded dragons significantly chose more than chance the food portion included in the small plate suggesting a human-like perception of the Delboeuf illusion (a). Bars represent the standard error. The asterisk (*) denotes a significant departure from chance level.

492

493 **Table 1. Information of the Bearded Dragons Participating in the Study and Individual Performance.**

SUBJECT	Control A	Control B	Control C	Test trials
Shuriken	12/16, $\chi^2 = 4.000, p = 0.047 *$	12/16, $\chi^2 = 4.000, p = 0.047 *$	12/16, $\chi^2 = 4.000, p = 0.047 *$	12/16, $\chi^2 = 4.000, p = 0.047 *$
Malie	11/16, $\chi^2 = 2.250, p = 0.134$	12/16, $\chi^2 = 4.000, p = 0.047 *$	11/16, $\chi^2 = 2.250, p = 0.134$	12/16, $\chi^2 = 4.000, p = 0.047 *$
Nimoy	6/16, $\chi^2 = 1.000, p = 0.317$	9/16, $\chi^2 = 0.250, p = 0.617$	11/16, $\chi^2 = 2.250, p = 0.134$	11/16, $\chi^2 = 2.250, p = 0.134$
Quadra	12/16, $\chi^2 = 4.000, p = 0.047 *$	10/16, $\chi^2 = 1.000, p = 0.317$	14/16, $\chi^2 = 9.000, p = 0.003 *$	8/16, $\chi^2 = 0.000, p = 1.000$
Norbert	12/16, $\chi^2 = 4.000, p = 0.047 *$	10/16, $\chi^2 = 1.000, p = 0.317$	13/16, $\chi^2 = 6.250, p = 0.012 *$	13/16, $\chi^2 = 6.250, p = 0.012 *$
Dr. Tom Pike	11/16, $\chi^2 = 2.250, p = 0.134$	12/16, $\chi^2 = 4.000, p = 0.047 *$	13/16, $\chi^2 = 6.250, p = 0.012 *$	12/16, $\chi^2 = 4.000, p = 0.047 *$
Alberta	13/16, $\chi^2 = 6.250, p = 0.012 *$	11/16, $\chi^2 = 2.250, p = 0.134$	12/16, $\chi^2 = 4.000, p = 0.047 *$	11/16, $\chi^2 = 2.250, p = 0.134$
Heinz	14/16, $\chi^2 = 9.000, p = 0.003 *$	11/16, $\chi^2 = 2.250, p = 0.134$	N/A	13/16, $\chi^2 = 6.250, p = 0.012 *$
Cecilia	12/16, $\chi^2 = 4.000, p = 0.047 *$	11/16, $\chi^2 = 2.250, p = 0.134$	N/A	10/16, $\chi^2 = 1.000, p = 0.317$
Oscar	15/16, $\chi^2 = 12.250, p = 0.0004 *$	13/16, $\chi^2 = 6.250, p = 0.012 *$	13/16, $\chi^2 = 6.250, p = 0.012 *$	12/16, $\chi^2 = 4.000, p = 0.047 *$
Mushu	13/16, $\chi^2 = 6.250, p = 0.012 *$	11/16, $\chi^2 = 2.250, p = 0.134$	10/16, $\chi^2 = 1.000, p = 0.317$	9/16, $\chi^2 = 0.250, p = 0.617$
Haku	13/16, $\chi^2 = 6.250, p = 0.012 *$	13/16, $\chi^2 = 6.250, p = 0.012 *$	N/A	12/16, $\chi^2 = 4.000, p = 0.047 *$

494 *Note:* Control trials = frequency of choices for the larger quantity; Test trials = frequency of choices for the
 495 portion of food on the smaller plate

496 *denotes a significant departure from chance at chi-square test ($p < 0.05$).

497

498

499

500

501

502 **Table 2. Information of the Red-footed Tortoises Participating in the Study and Individual Performance.**

503

SUBJECT	Control A	Control B	Test trials
6 (Savina)	12/16, $\chi^2 = 4.000, p = 0.047 *$	8/16, $\chi^2 = 0.000, p = 1.000$	8/16, $\chi^2 = 0.000, p = 1.000$
7 (Patty)	8/16, $\chi^2 = 0.000, p = 1.000$	9/16, $\chi^2 = 0.250, p = 0.617$	7/16, $\chi^2 = 0.250, p = 0.617$
8 (Charles)	12/16, $\chi^2 = 4.000, p = 0.047 *$	6/16, $\chi^2 = 1.000, p = 0.317$	11/16, $\chi^2 = 2.250, p = 0.134$
9 (Mozart)	9/16, $\chi^2 = 0.250, p = 0.617$	8/16, $\chi^2 = 0.000, p = 1.000$	8/16, $\chi^2 = 0.000, p = 1.000$
10 (Seisue)	8/16, $\chi^2 = 0.000, p = 1.000$	8/16, $\chi^2 = 0.000, p = 1.000$	7/16, $\chi^2 = 0.250, p = 0.617$
19 (T19)	9/16, $\chi^2 = 0.250, p = 0.617$	10/16, $\chi^2 = 1.000, p = 0.317$	8/16, $\chi^2 = 0.000, p = 1.000$
24 (Ranieri)	3/16, $\chi^2 = 6.250, p = 0.012 *$	8/16, $\chi^2 = 0.000, p = 1.000$	8/16, $\chi^2 = 0.000, p = 1.000$
300 (Gerard)	9/16, $\chi^2 = 0.250, p = 0.617$	12/16, $\chi^2 = 4.000, p = 0.047 *$	9/16, $\chi^2 = 0.250, p = 0.617$

504 *Note:* Control trials = frequency of choices for the larger quantity; Test trials = frequency of choices for the
 505 portion of food on the smaller plate

506 *denotes a significant departure from chance at chi-square test ($p < 0.05$).

507